

# Light Signalling System

## Manual

AVISO Bee



### **SILENT SPECTRUM**

76 Keeverstone Court

97 Manor Road, Bournemouth, Dorset BH1 3BZ

E-Mail : [r.everingham@btinternet.com](mailto:r.everingham@btinternet.com) or [kompone@btinternet.com](mailto:kompone@btinternet.com)

[www.avisobee.co.uk](http://www.avisobee.co.uk)

# **AVISO Bee**

## Manual and Installation Instructions

<b>Contents</b>	<b>Page</b>
<b>1 General instructions</b>	03
1.1 Function	03
1.2.Safety instructions	03
1.3.Cleaning and care	03
<b>2 Preparation for installation</b>	04
2.1 Transmitter - AVISO Bee Uni / Uni Bee AVISO - M	04
2.2 Transmitter - connecting the door bell or house phone voltage 2V - 40V	04
2.3 Transmitter - connecting the door bell - voltage 40V	05
2.4 Transmitter - Connecting to the telephone network: using the AVIS Bee Teladapter	06
2.5 Receiver - using the light signals on the receiver	06
2.6 Receiver - AVISO Bee Flash / Flash AVISO Bee-C	07
<b>3 Creating a connection</b>	08
3.1 Re installing the system	08
3.2 Connecting/removing AVISO BEE parts in an existing system	09
<b>4 Using the display</b>	10
4.1 Events	10
4.2 DIP – switch – assigning the transmitter	11
4.3 The control panel	12
<b>5 Errors</b>	12
5.1 AVISO BEE FLASH missing component error display	12
5.2 AVISO BEE FLASH transmitter – no or low battery error display	13
5.3 AVISO BEE relocation of equipment error display	13
5.4 Resetting the AVISO BEE FLASH [-C] receiver	14
5.5 Resetting the AVISO BEE transmitter	14
<b>6 Warranty</b>	14
<b>7 Appendix</b>	15
7.1 Declaration of conformity	15
7.2 Trademarks	16
7.3 Liability	16

## **1. General information**

Thank you for purchasing the AVISO BEE light signalling system. Installation of your system is really simple. Your transmitters are delivered pre configured and are designed to be easily set up by the purchaser. However, if you are unsure about any aspect of installation or if you need any help do not hesitate to contact your dealer.

### **1.1. Function**

Your AVISO BEE lighting system consists of 2 types of devices, **Transmitters** and **Receivers**. Transmitters detect signals from events such as a ringing phone or fax or a ringing doorbell and transmit radio signals to activate the receivers. The receivers convert the radio signals into light signals to alert the user to the event.

The minimum system comprises of one transmitter and one receiver but if required, it is easily possible to operate several devices in one house.

### **1.2. Safety instruction**

Receivers are mains operated and you should never open your AVISO BEE FLASH [-C]! All our devices are designed to be maintenance free. In the rare event your device does not work as expected please have it checked by the authorised workshop.

### **1.3. Cleaning and care**

Use only a soft, slightly damp cloth to clean your devices.

**All mains operated components must be disconnected from the mains before cleaning.**

Do not use harsh detergents which could damage the equipment.

## **2.Preparing for installation**

Do not position your AVISO BEE components in **close proximity** to other devices using radio communication, such as cordless phones or wifi access points as these could compromise the performance of your AVISO BEE system.

### **2.1. Transmitter – AVISO BEE UNI or AVISO BEE UNI – M**

Select a suitable position to mount the transmitter using the mounting straps supplied. We recommend placing the transmitter above floor level to achieve the optimum radio connection.

The AVISO BEE UNI transmitter [Universal transmitter] offers you a selection of connection options. The transmitter can detect both AC and DC signals across a range of 0-40V, as used in the majority of doorbells, computer signals, and other common sources. It can also connect and disconnect coupling contacts and a variety of events such as fire alarms, personal callers, etc. For bells of 230V [or more than 40V] you will need to utilise the separately supplied microphone.

The AVISO BEE transmitter BEE UNI – M [microphone transmitter] has a wide range of connection options. It contains a built-in microphone, and is therefore particularly suitable for use with bells that have a working voltage of 230V [or more than 40V].

Your dealer can pre set the transmitter to your exact requirements.

### **2.2 Transmitter – connecting a doorbell or home phone with a voltage of 2V – 40V**

To directly connect the transmitter to the doorbell the supplied AVISO BEE CABLE is required. The free ends of the cable are installed into the doorbell, as illustrated in the diagram below. The opposite end of the cable is fitted with a jack plug that should be fitted into the right slot [2] on the top of the transmitter. See the diagram below.

After connection [page 8] it is possible to regulate [7] the level of sensitivity of the transmitter.

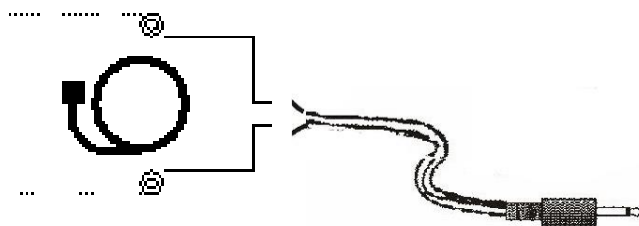

Install doorbell

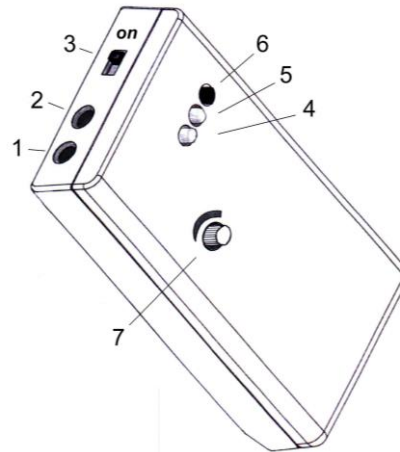

Your **home phone** can also be connected using the AVISO BEE CABLE. To do this fix [or solder] the free ends of the cable directly to the speakerphone.

### 2.3. Transmitter – connecting a doorbell with a voltage greater than 40V

**ATTENTION!** Doorbells with an operating voltage greater than 40V should **never** be connected directly to the transmitter using the AVISO BEE CABLE. To do so could seriously damage the unit.

You are instead advised to use the transmitter AVISO BEE UNI – M [microphone] or the AVISO BEE UNI [2] with an external microphone.

The AVISO BEE UNI – M transmitter mounting edge is supplied with preformed location holes for fitting the microphone and is supplied with fixing strips.

If you use an external microphone with the AVISO BEE UNI attach your external microphone with the double-sided adhesive tape that is supplied with the microphone onto the doorbell or speaker. Plug the opposite end of the cable with the jack connector into socket [2] on the transmitter.

After connection [page 8] it is possible to regulate [7] the level of sensitivity of the transmitter.













#### 2.4. Transmitter – connecting the AVISO BEE - TEL ADAPTER [Telad]to the telephone network:

Connect the AVISO BEE TELAD using the black cable into the left slot [1] of the AVISO BEE UNI transmitter. Connect the opposite end to the telephone socket.

#### 2.5. Receiver - using the light signals on the receiver

The AVISO BEE FLASH [-C] receiver alerts the user to events as they occur. The receiver has three LED indicators, red, yellow and green. These alert the user to which exact event is occurring, [phone, doorbell, etc.].

The following table gives an overview of the use of assigned colours to individual signalling events. These can be individually assigned according to client preference.

Event	LED-show			Light/flashes
	Red	Yellow	Green	
Telephone (Teladapter socket 1)				fast, gap approx. 0.8 Sec
Fax / Mobile				8 x fast,gap approx. 0.8 Sec
Doorbell 1 (AVISO Bee Uni / Uni -M)				8 x slowly,gap approx. 3.2 Sec
Doorbell 2				4 x slowly,gap approx. 3.2 Sec
Baby cry, according to the intensity of the crying (AVISO Bee baby)				irregular flashing, according to the intensity of the crying
Personal caller (Call-AVISO)				2 x fast, repeat
Smoke alarm				8 x fast, gap approx. 0.8 Sek.

 = LED light on permanently,       = LED light flashing

In cases where transmitters transmit two separate events occurring concurrently, the receiver displays the events in sequence.

More explanation on page 10 and 11.

## 2.6 Receiver

The AVISO BEE FLASH is designed for plugging directly into a 230V socket using the AVISO BEE FLASH – C power cable

Receivers with flashes and three LEDs [2] for recognising signals.

The AVISO BEE FLASH is designed to be suitable for rooms in which the mains socket (230V) is not easily visible or close to the floor.

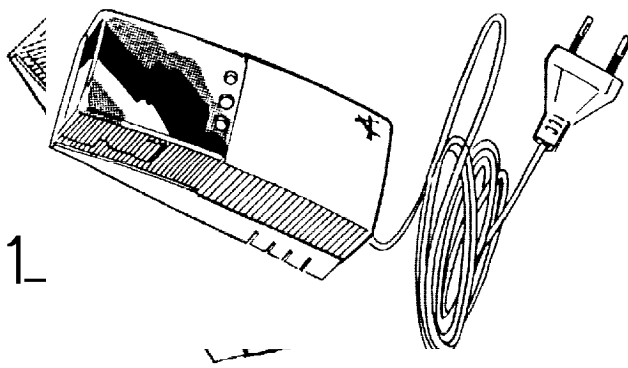

The AVISO BEE FLASH receiver can be sited at eye level.

The AVISO BEE FLASH – C with 1.5m cable 230V can be placed on a shelf, a bedside table, or fixed with screws on the wall. **(Do not plug the**

**unit into the mains until it is safely sited in its preferred position.)**

### W

**For wall mounting the AVISO BEE FLASH – C**

Use the screws supplied [3.5x25mm].

(see AVISO BEE FLASH - C figure below)

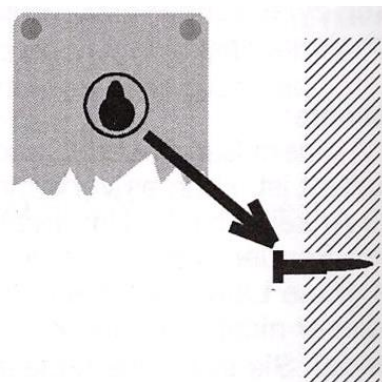

### 3. Creating a connection

#### 3.1. New installation of system

Note: the basic system consists of at least one transmitter and one receiver.

##### AVISO BEE

First plug the AVISO BEE FLASH receiver into a mains electricity socket. A continuous flashing red LED denotes the unit is functioning correctly.

The system is now in the login mode.

If you purchased multiple AVISO BEE FLASH [-C] receivers plug each into a mains electricity socket in the same way.

If the connection to the first flash AVISO BEE [-C] is successful, the next receiver starts flashing the green LED diode. If the red LED diode is flashing the signal is probably too weak. In this case remove the receiver from the mains socket and plug it into a different socket closer to the first receiver. It is possible to use a bridge for larger distances between transmitter and receivers. Each AVISO BEE FLASH acts as a relay.

If you have successfully connected all the receivers to mains electricity sockets you can now log the system into the transmitter. The transmitter must be connected to a signal source [door-bell, telephone etc] [Chapter 2].

Then turn ON the transmitter power using the switch [3] and briefly press the test button [6]. The transmitter will now log into the system as denoted by the green LED diode flashing on the transmitter [5].

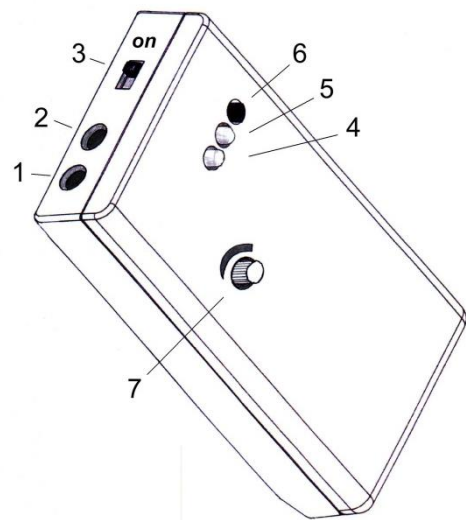

If logging into the system is unsuccessful, the red LED diode on the transmitter will flash five times [4].

In this case, make sure the system is in the log in mode (the AVISO BEE FLASH receiver flashes the red or green LEDs).

If not, reduce the distance to the nearest AVISO BEE FLASH or the distance between the transmitter and receiver, or plug in another AVISO Bee flash .

Note: The log in mode runs until the first unit logs into the system transmitter. The system transmitter maintains log in time for two minutes after each successful login into the system transmitter.

After two minutes, the log in mode automatically ends .

The system is now ready for operation.

Check out all the signal sources and, if necessary, adjust the microphone transmitter sensitivity using the controller (7), as described on page 5.

### **3.2. Connecting/removing AVISO BEE parts in an existing system**

If you want to add or remove a transmitter or receiver from the system press any transmitter test button [6] briefly for 5 seconds until the green LED flashes [5]

Successful registration is confirmed by a short flash of the green LED diode on the transmitter.

If the red LED diode flashes on the receiver, it is probably a weak contact signal to the transmitter. Remove the receiver from the wall socket and plug in to a socket closer to first receiver.

The AVISO BEE FLASH can act as a relay for longer distances as a **bridge** between the transmitter and a receiver.

Two minutes after logging in the final unit the system will return to normal operation mode.

You can check this by using the test button or by creating an event. [doorbell, telephone, etc.]

## 4. Using the display

### 4.1. Events

Each individual event is indicated on the receivers by its own combination of different coloured LEDs flashing.

#### 1) Doors

<u>Door</u>	<u>Indication</u>	1. Tact	2. Tact	3. Tact	4. Tact
<b>1</b>	Flash	•			
	Green				
	Yellow				
	Red				
<b>2</b>	Flash	•			
	Green				
	Yellow				
	Red				
<b>3</b>	Flash	•			
	Green				
	Yellow				
	Red				

1 sequence = 4 tact after 0.8 second

#### 2) Communication equipment

	<u>Indication</u>	1. Tact	2. Tact	3. Tact	4. Tact
<b>Telephone</b>	Flash	•	•	•	•
	Green				
	Yellow				
	Red				
<b>Fax</b>	Flash	•	•	•	•
	Green				
	Yellow				
	Red				

1 sequence = 4 tact after 0.8 second

### 3) Alarm

	<b>Indication</b>	1. <b>Tact</b>	2. <b>Tact</b>	3. <b>Tact</b>	4. <b>Tact</b>
<b>Caller</b>	Flash	●	●		
	Green	■	■	■	■
	Yellow				
	Red	■	■	■	■
<b>Fire</b>	Flash	●	●	●	●
	Green	■	■	■	■
	Yellow	■	■	■	■
	Red	■	■	■	■

1 sequence = 4 **tact** after 0.8 second

### 4.2 DIP-Switch – assigned to transmitter

SB1	SB2	<b>Entrance</b>
0	0	Jack 1 (short-circuit)
0	1	
1	0	
1	1	External microphone jack 2

SB3	<b>Transmitter</b>
0	Normal operation
1	transmitter

SB4	SB5	<b>LED Green / Red</b>
0	0	Only green LED
0	1	Only red LED
1	0	Red and green alternating
1	1	No red, no green

SB6	SB7	SB8	<b>LED Yellow</b>
0	0	0	No yellow LED
0	0	1	Always yellow LED
0	1	0	1 x short flash
0	1	1	2 x short flash
1	0	0	3 x short flash
1	0	1	4 x short flash
1	1	0	2 x long flash

SB9	SB10	<b>Repeat</b>
0	0	1 x
0	1	4 x
1	0	8 x
1	1	to 20 minute, or cancel

### 4.3. Control panel

#### AVISO BEE FLASH log in mode [coordinator]

<u>Indication</u>	1. Tact	2. Tact	3. Tact	4. Tact
Flash				
Green				
Yellow				
Red				

1 sequence = 4 tact after 0.8 second

#### AVISO Bee Flash login mode (router)

<u>Indication</u>	1. Tact	2. Tact	3. Tact	4. Tact
Flash				
Green				
Yellow				
Red				

1 sequence = 4 tact after 0.8 second

## 5. Error display

Your system is equipped with the AVISO BEE control function that continuously monitors the communication between the individual components of your AVISO BEE network.

If communication between the individual units is disturbed or a unit is missing, or if the transmitter battery needs recharging or replacing this will trigger an error display on the receiver. This is shown by the green or red LEDs flashing as illustrated below.

### 5.1 AVISO Bee Flash – missing component display

<u>Indication</u>	1. Tact	2. Tact	3. Tact	4. Tact
Flash				
Green				
Yellow				
Red				

1 sequence = 4 tact after 0.8 second

Reasons:

The unit will flash if it is removed from the mains socket or if there is interference or an interruption to the radio communications.

To permanently remove an AVISO BEE FLASH unit it is necessary to switch the system into login mode. [see page 9] by pressing the control button on any transmitter for 5 second.

## 5.2 AVISO BEE UNI transmitter - missing or depleted battery error display

<u>Indication</u>	1. Tact	2. Tact	3. Tact	4. Tact
Flash				
Green				
Yellow				
Red				

1 sequence = 4 tact sfter 0.8 seconds

You can check your AVISO BEE UNI transmitter by briefly pressing the control button [6].

If after a few seconds the green LED diode on the transmitter lights and the AVISO BEE FLASH receiver flashes, the transmitter is functioning correctly. If the red LED diode on the receiver [4] flashes five times, this indicates there is no radio link between the transmitter and receiver.

A continuously flashing red LED diode indicates low battery power in the transmitter. In this case the battery needs replacing. The battery in your transmitter should last for approximately 7 years.

## 5.3 Relocation of equipment [moving]

Your pre configured and functioning AVISO BEE system can easily be relocated to other locations.

To relocate your system turn OFF the main switch on the transmitter [3] and unplug the receiver(s). The system is now ready to move.

Once you have relocated all the receivers and transmitter switch ON the transmitter, then the receivers. Then test the transmitter by briefly pressing the test button [6]. After a few seconds the green LED diode will flash. The green LED diode will stop flashing when the process is complete.

#### **5.4. Resetting the AVISO BEE FLASH [-C] receiver**

On rare occasions the AVISO BEE FLASH receiver may need to be reset [for example where components have been connected incorrectly]

Procedure:

1. Remove the AVISO BEE FLASH from the mains electrical socket
  2. Unscrew the holding screw to open the cover
  3. Set the DIP-FIX switch to connect, then refit and screw down the cover
  4. Plug the AVISO BEE FLASH back into the mains socket
  5. The AVISO BEE FLASH will confirm a successful reset by flashing all three LEDs [red, yellow, green]
  6. Remove the AVISO BEE FLASH from the mains socket
  7. Re open the cover and set the DIP-FIX switch to disconnect
  8. Refit and screw down the cover as before and plug back into the mains
- The AVISO BEE FLASH is now ready to log into the AVISO BEE system

#### **5.5 Resetting the AVISO BEE transmitter**

On rare occasions the AVISO BEE FLASH transmitter may need to be reset [for example where components have been connected incorrectly]

procedure:

1. Switch off the transmitter using the main switch
2. Press and hold the test button and turn ON the main switch (3)
3. Both LED diodes will flash
4. Then release the test button
5. Switch the power back on

The AVISO BEE FLASH is now ready to log in into the AVISO BEE system

### **6. Warranty**

The warranty covers the 2 year period from the date of purchase.

Your warranty is limited to the replacement or repair of defective products by an authorised service supplier. The costs of returning units for service are the responsibility of the customer.

We endeavour to supply an extremely reliable product.

We cannot, however, guarantee the correct functioning of the product in all particular circumstances.

All warranties are void in the case of improper use of the product, eg. wrongly connecting the transmitter to the signal source [such as directly connecting to the 230V mains supply].

### **7. Appendix**

## 7.1. Declaration of conformity

Silent Spectrum partnership are the importer of radio equipment under the provision of Government regulation no.426/2000 and no.483/2002 amended by Government

Government decree no.251/2003 - technical requirements for radio equipment and telecommunications terminal equipment declares, that this product AVISO BEE meets the requirements of the General Licence Office GL-1/R/2000 and also meets the requirement of standards and regulations relevant to equipment of this type.

Radio compatibility parameters: ETSI EN 301 419-1, EN 301 511 in 7

EMS: ETSI EN 301 4898-7, IES 55022, EN 50130-4

Electrical safety: EN 50609

This equipment is safe under normal use and in accordance with the instructions.

This declaration is issued under the sole responsibility of the manufacturer.

This Declaration of Conformity is issued on the basis of the following documents:

EN 60950-1:2006 Information technology equipment - Safety  
Part 1: General requirements

The equipment is safe under normal use and in accordance with the instructions. Compliance was assessed in accordance with paragraph 3, 1, letter a] Annex 3 of Government no.426/200 . Technical requirements for radio equipment and telecommunication terminal equipment.

This declaration is issued under the sole responsibility of the manufacturer.

Declaration of Conformity is issued on the basis of the following documents:

EN 60950-1:2006 Information technology equipment - Safety  
Part 1: General requirements

### Spurious interferences

CISPR 22, class B

CISPR 22, class B

IEC 61000-3-2

IEC 61000-3-3

## Immunity against interferences

IEC 61000-4-2  
IEC 61000-4-3  
IEC 61000-4-4  
IEC 61000-4-5  
IEC 61000-4-6  
IEC 61000-4-11

## Radio transmission

ETSI EN 300 328 V1.7.1 (2006-10)

CH-8636 Wald, Juli 2009

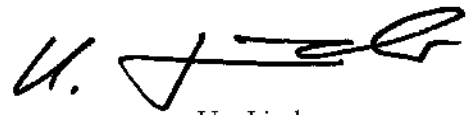

Urs Linder

### **7.2. Trademarks**

AVISO is an international trade mark [Depot No.626372]  
Design device – AVISO system is protected [Mod.Dep.DM/029  
No.207]

### **7.3. Liability**

We accept no responsibility for faults and defects that are caused directly or indirectly by inappropriate usage. We also do not assume liability for damages and disturbances that occur when using the equipment on other devices.

For product support and help visit our website at [www.avisobee.co.uk](http://www.avisobee.co.uk)

Silent Spectrum  
76, Keverstone Court  
97 Manor Road, Bournemouth,  
Dorset BH1 3BZ

kompone@btinternet.com



August 2021